

## Chair Adjustment Guide: Cerra XT Synchro Knee-Tilt Control

### Series XT

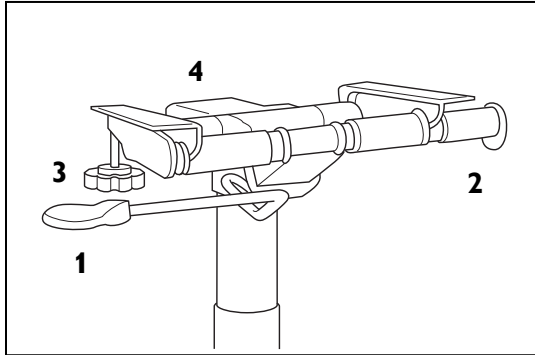

#### Mechanism Functions:

1. Seat Height
2. Tilt Lock
3. Tension Control Knob
4. Back Height Adjustment

1. **Seat Height** adjustment easily raises or lowers seat to desired height. To raise, simply lift weight off seat and pull upward on lever until seat reaches a comfortable height. To lower, lift upward on lever while seated and release to lock seat into desired position.
2. **Tilt Lock** lever secures seat into starting position or allows seat to free float. To release, pull lever outward.
3. **Tension Control Knob** allows for greater spring tension control for a firmer or softer tilting motion. Turn counterclockwise to increase tension, clockwise to decrease tension.
4. **Back Height** adjustment repositions back into multiple increments. To raise back height, simply lift upward on back until desired height is reached. To return to lowest position, raise chair-back to highest level and release to lowest position.

\*Optional Seat Slider adjustment (not pictured) provides 2½" front and back horizontal seat depth adjustment. To operate, lift up on adjustment bar and move seat forward or backward until desired depth is achieved. Release bar and seat will lock into position.